

The Windfighter™

The Windfighter™ Post System XG1 and XL2

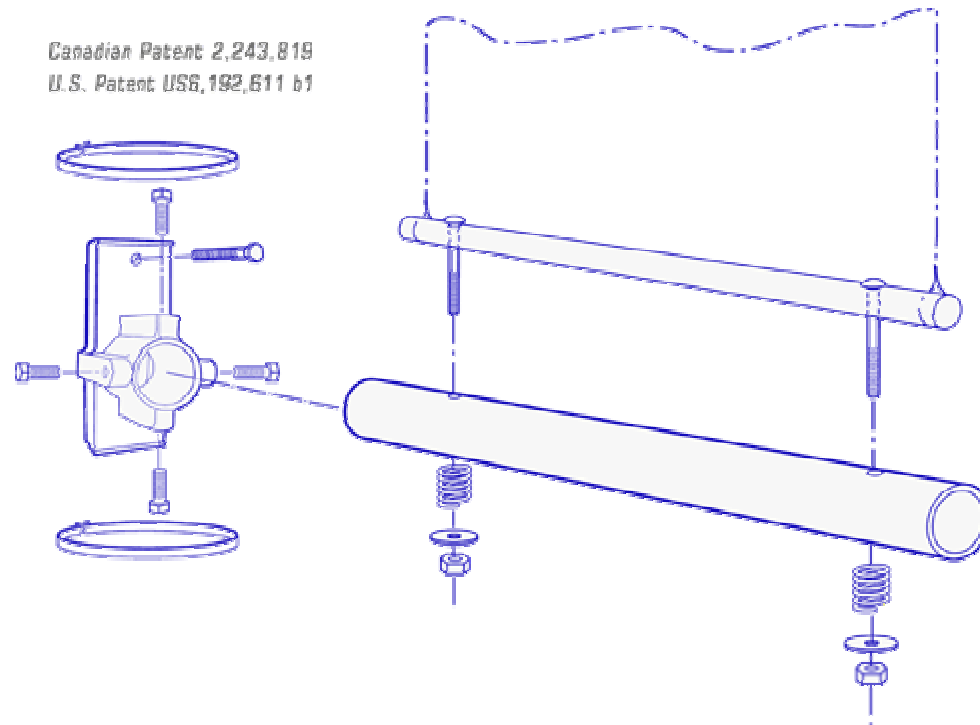

Made from engine grade aluminum and galvanized steel, this Windfighter™ post system gives your banner a full suspension system. With 400 pounds of pressure, the springs keep your banners and flags flat and straight at all times. No need for wind holes. With this system, your banner will have the appearance of a rigid sign and will be protected from the wind! It will not sag nor tear.

The XG1 system is designed to accommodate banners of up to 3ft x 10 ft

The XL2 system is designed to accommodate banners of up to 5 ft x 20 ft

The one and only post system of its kind on the market

The Windfighter™ post system is the easiest to install and the most resistant banner hardware on the market. The Windfighter™ distributes stress and tension and keeps your banner smooth and flat under all wind conditions. The system's durability and flexibility is such that a growing number of municipalities, retailers, automobile dealerships, museums and other image sensitive corporations are now requiring Windfighter™ products.

The Windfighter™ corner +

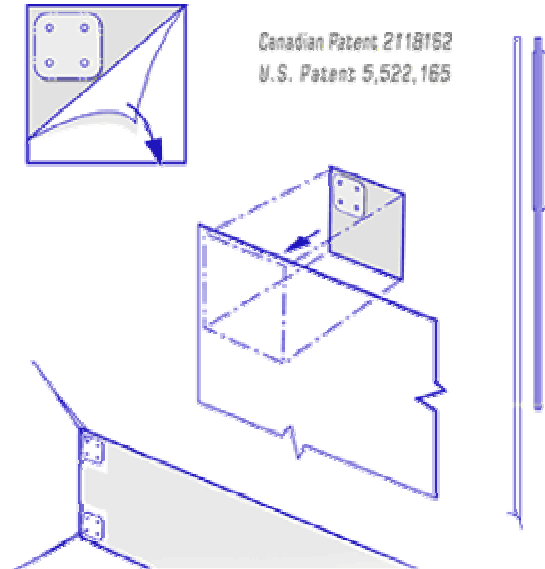

Canadian Patent 2118162
U.S. Patent: 5,522,165

Apply the Windfighter™ corner + in a minute and turn your banner in to an indestructible artwork!

Materials:

Vinyl white opaque 30 oz / per square yards
matte finish.

Reinforced double side tape sc-211y 48mm

Reinforced Fiberglass

Reinforced vinyl 1000 deniers 9x9 screen

Polyester 1000 deniers

9X9 screen

Wind resistance: 50 l (wind 70 mph)

Tear Resistance: 210 l x 200 l

Cold Resistance: -45 F

Flame retardant: F-306.02

UV stable

The Windfighter™ banner systems are part of a unique product line that is the most revolutionary yet. With its reinforced corners to distribute stress and a tension system that keeps the banner smooth and flat under all wind conditions, the Windfighter™ systems behave more dynamically than a traditional banner. In fact, our products allow you to turn your banner products into the most wind resistant banners on the North-American market. From now on, your banner will act like the wing of an aircraft; it will harness the power of the wind and transforming your banner into the most efficient, most resistant and most reliable outdoor/indoor means of communication.

The first banner improvement that will give you and your business the edge

The Windfighter™ corner+ is a very innovative and fully reinforced fiberglass corner insert that is glued to your vinyl banner. This super strong insert reinforces the corner of the banner and makes the Windfighter™ system virtually indestructible. This 5 minute modification will transform all of your products. From now on, your banners will always be flat and straight, no matter the weather.

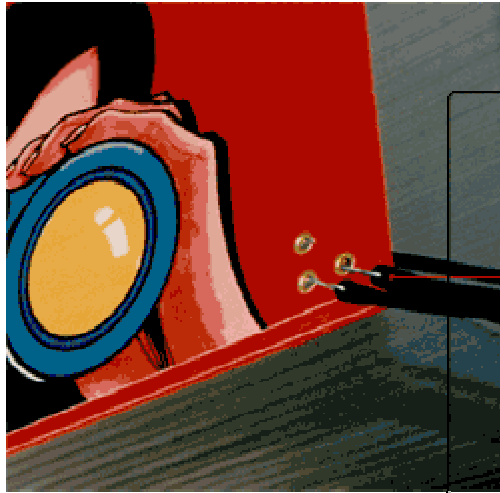

Canadian Patent 2118162
U.S. Patent 5,522,185

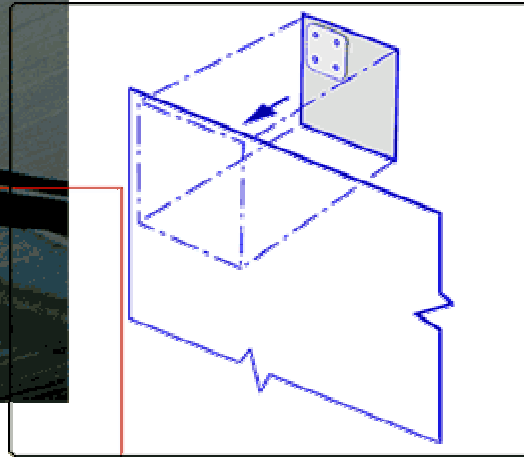

The first banner improvement that will give you and your business the edge

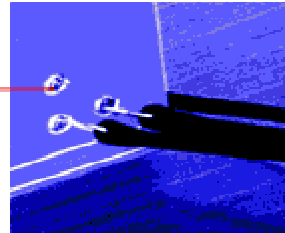
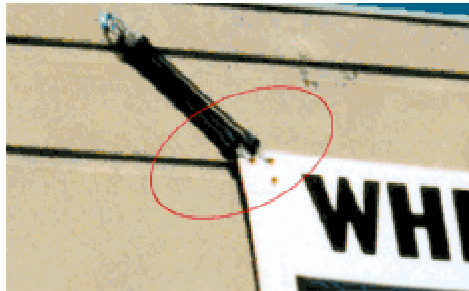

This banner installed in
Winnipeg is 40 ft x 80ft
(Look closely at the man at the
bottom left of the banner!)

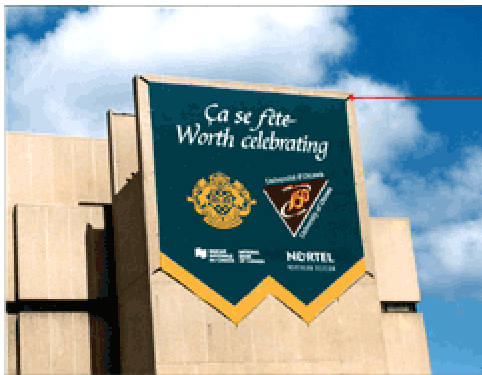

Banner 30 ft x 30 ft
with re-enforced
corner



Winnipeg Airports Authority unveils the world's
largest 1999 Pan American Games banner
at the airport yesterday.

The Frameless Windfighter™ system

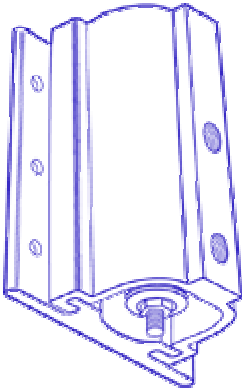

Canadian Patent 2,243,819
U.S. Patent US6,192,611 b1

The revolutionary Windfighter™ frameless system!!

The Frameless Windfighter™ system is our latest technology. It is the only system that allows you to install your banner on a wall without a frame and without screws every 2 ft. Based on our post system, this wall system has a full independent suspension behind the banner. It keeps your banner solidly anchored, smooth and flat 24hrs a day. Furthermore, this system also resists high winds and weather extremes.

This system can also be combined with the Windfighter™ corner+ system for extreme conditions and oversize banners.

The Frameless wall system - Another exclusive Windfighter™ innovation

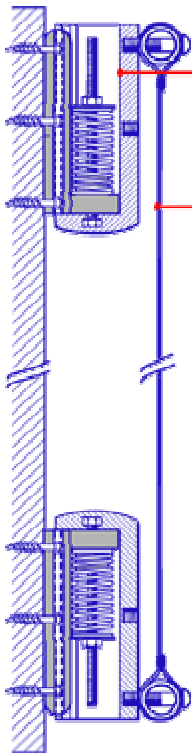

The frameless system is similar to the post system: it keeps the wall banner flat and straight all the time. Located behind the banner, the system is invisible and your banner is more aesthetically pleasing.

Banner

Canadian Patent 2,243,819
U.S. Patent US6,192,611 b1

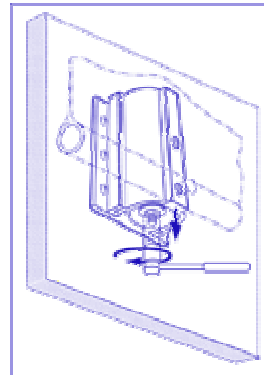
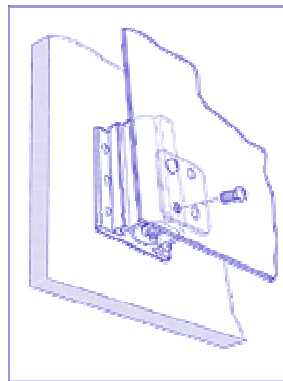

Unlimited possibilities: Use the frameless system with the Windfighter™ corner+ banners or the pole pocket banners.

The frameless system is similar to the post system: it keeps the wall banner flat and straight all the time. Located behind the banner, the system is invisible and your banner is more aesthetically pleasing.



The Frameless Windfighter™ system is the future standard for wall banner installation. It prevents damage to your property and it is easy to install. Like the post system, the frameless system distributes stress and tension and keeps your banner smooth and flat under all wind conditions.

- Made of durable aluminum and steel that resists corrosion
- Your banner will convey the message better because:
- Installation and removal of various banners for different seasons or events is readily done
- The system take less than 30 minutes to install
- It accommodates unlimited size banners

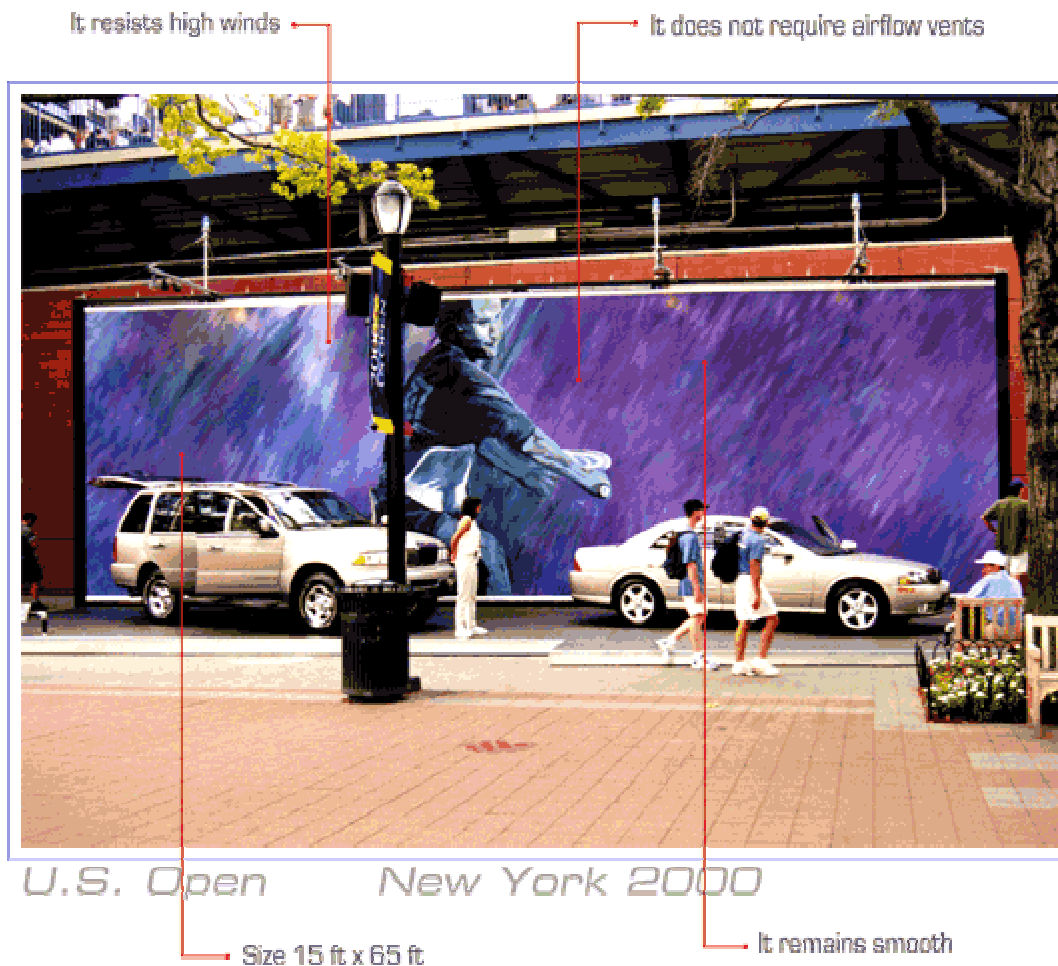



Windfighter™ support when you need it; 24/7.

Product warranty

Windfighter™ products are backed by the most comprehensive warranty and support in the industry. Windfighter™ promises a well designed and durable graphics display solution that provides high impact and reliability.

A Quality Promise from Windfighter™

When you choose the Windfighter™ products, you'll know that every component has been designed, developed, tested and manufactured for superior performance and durability. The result is a range of products that are easy to install and superior to any banner system on the market. With Windfighter™ products you can create graphics displays that meet your needs from short-term promotional to long-term durable installations.

Quality and guaranteed performance

We're so confident that our products will meet your high quality standards that we guarantee the performance of the entire banner system for one full year. No fine print. Just quality and performance guaranteed. This is the Windfighter™ pledge of quality and warranty.

Peace of mind

When you purchase the Windfighter™ products, you purchase peace of mind. Our warranty is your assurance that every component works well together. And if there's a problem, we'll fix it. Guaranteed.

Windfighter™ products are covered by our comprehensive warranty when the banner systems are installed following the Windfighter™ installation methods with Windfighter™ tools and adhesives.

Time and weather tested, our products have a proven and unsurpassed reliability and durability.

Windfighter Banner Systems are currently in use at The Port of Montreal with no issues during the past 5 years. Windfighter has survived ice storms and major winds at Halifax Car Dealerships. The Windfighter Banner System was recently chosen as the system of choice by the Museum of Civilization in Ottawa and the Ford utilized the Frameless System at the US Open Tennis Championships in New York City.